

# AC 170



The state of the art over  
varnishing / basecoating machine  
for aluminium tubes or cans

# The cost-efficient way to varnish aluminium tubes or cans

- // Designed for fast laquer and diameter change over
- // Robust and durable construction for consistent varnish quality
- // Mechanical drive concept ensures easy service
- // Compact machine design

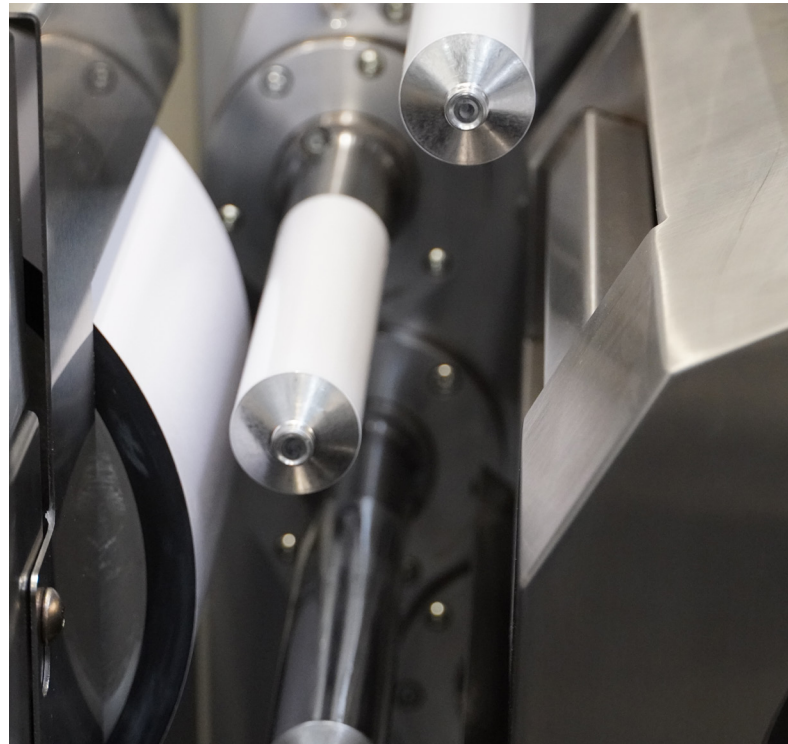
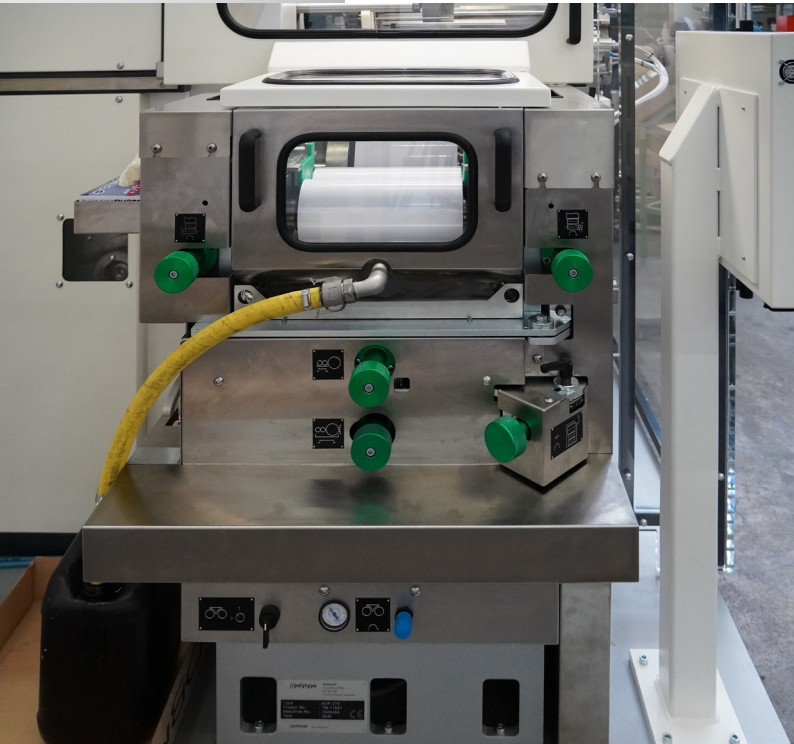

## Specification of AC 170

### Product range aluminium tubes

- // Ø Small- / Large range: 11-25 mm / 19-45 mm
- // Skirt length for small range: 50-160 mm
- // Skirt length for large range: 50-210 mm
- // Max. head height: 30 (40) mm
- // Lacquer height up to: 205 mm
- // Output speed up to 170/min

### Product range aluminium cans

- // Ø Small- / Large range: 35-53 mm / 45-66 mm
- // Skirt length for small range: 110-235 mm
- // Skirt length for large range: 110-260 mm
- // Max. head height: 30 (40) mm
- // Lacquer height up to: 260 mm
- // Output speed up to 170/min

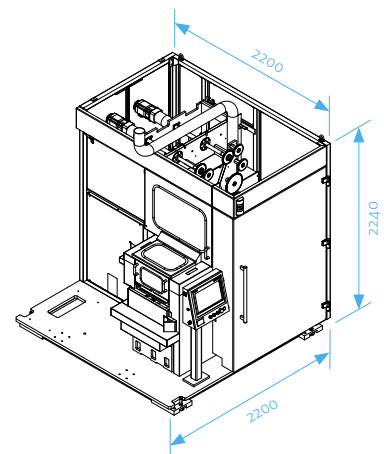

//polytype

mall//herlan

Mall + Herlan GmbH

Wöschbacher Strasse 33 | DE-76327 Pfinztal/Germany

Phone +49 721 946 01 0

info@mall-herlan.com | www.mall-herlan.com