

wifag//polytype group

Hi-Flex DWI 200



The new line for DWI aerosol cans

mall//herlan

DWI

Production lines for monoblock aerosol cans



mall//herlan is one of the world's leading producers of machines and complete production lines for monoblock metal packagings such as aerosol cans, bottles and tubes made from aluminium or steel.

mall//herlan is known for producing the highest quality products in conjunction with providing the highest quality of services for its customers. Each single employee is motivated to continuously improve the products and services offered by mall//herlan. This not only means that top-class industrial production lines are produced, but also new trends are constantly being set through continuous further development.

As a reliable partner and innovative trendsetter, mall//herlan is only interested to make our customers the most successful players in the industry. The company is more than happy to go that extra mile in order to ensure that its customers enjoy this success.

- // Production machines for cylinder forming, decoration, shaping and necking
- // Lightweight monoblock cylinders
- // Full process knowledge for aluminium and steel cans
- // Overall tooling competence in all forming processes
- // Highest reliability by best product quality and production efficiency
- // Customised line designs according to production site layout
- // Wide decoration variety, huge range of product shapes and finishes



Aluminium or steel from a coil enters at the front, and cans ready to be filled are the finished product at the end of the line – in a single continuous process. The line consists of three modules: the frontend produces the cylinder. In the decoration the lacquers and the print artworks are applied to the cylinder. The backend consists of necking and quality checks, including post-washing. mall//herlan owns the whole expertise to ensure that each single step of the production process, from the very beginning right through the very end of the line, runs perfectly.

Customised DWI production lines for steel and aluminium cans

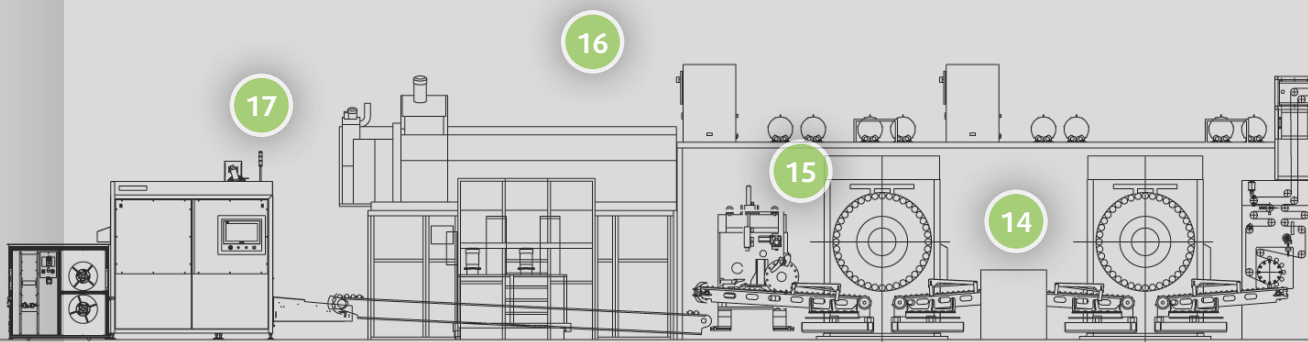

17 Packing machine

Cans may be bundled or palletised in several ways, as requested by our customers.



16 Post washer + dryer

Multiple chambers for washing and rinsing cans or bottles with water. The cleaning can be done with or without detergents. The patented nozzle injection system ensures optimum cleaning. The postwasher is eco-friendly and of food-grade standard



15 Leak detector

Detects microholes to ensure the can or bottle integrity: the photocell detects when rays of light fall into the cans. 100% quality-control.



14 Necker

The cylindrical can body is necked and shaped by necking dies up to the final can design. Several forming processes are possible: Threading, curling, beading, registered embossing and debossing to match the brand owner's design.

- // Strong, stable, adaptable and flexible cylinder making process
- // Optimized material utilization due to flexible tool arrangements
- // Reliable transfer systems
- // Energy-saving features
- // High-quality premium decoration
- // Huge necking and shaping varieties create unique shapes and designs
- // Easy access for quick size changes and maintenance

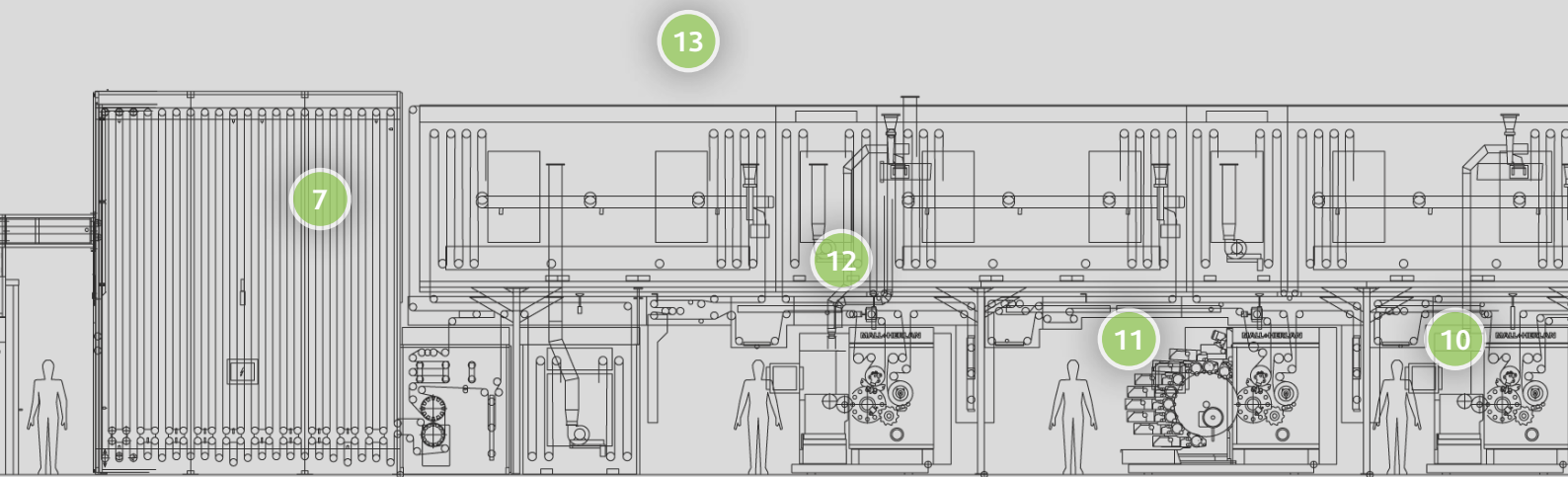

13 Oven + cooling zone

Lacquers and inks are hardened in drying ovens, which gives them their perfect optical appearance and makes them resistant to environmental influences.



12 Overvarnisher

Applies the overvarnish for protecting the inks and providing special effects like matt, semi matt, gloss and even haptic.



11 Printing machine

The printing unit, which can apply up to 9 colours, ensures the widest possible decoration variety for monoblock packagings. The decorator can be equipped optionally with a QC system to control printing quality.



10 Base coater

The cylinder receives the base coat which is important for the stain resistance and excellent print quality.



9 Internal coat dryer

Cures and hardens the inside lacquer to guarantee product safety.

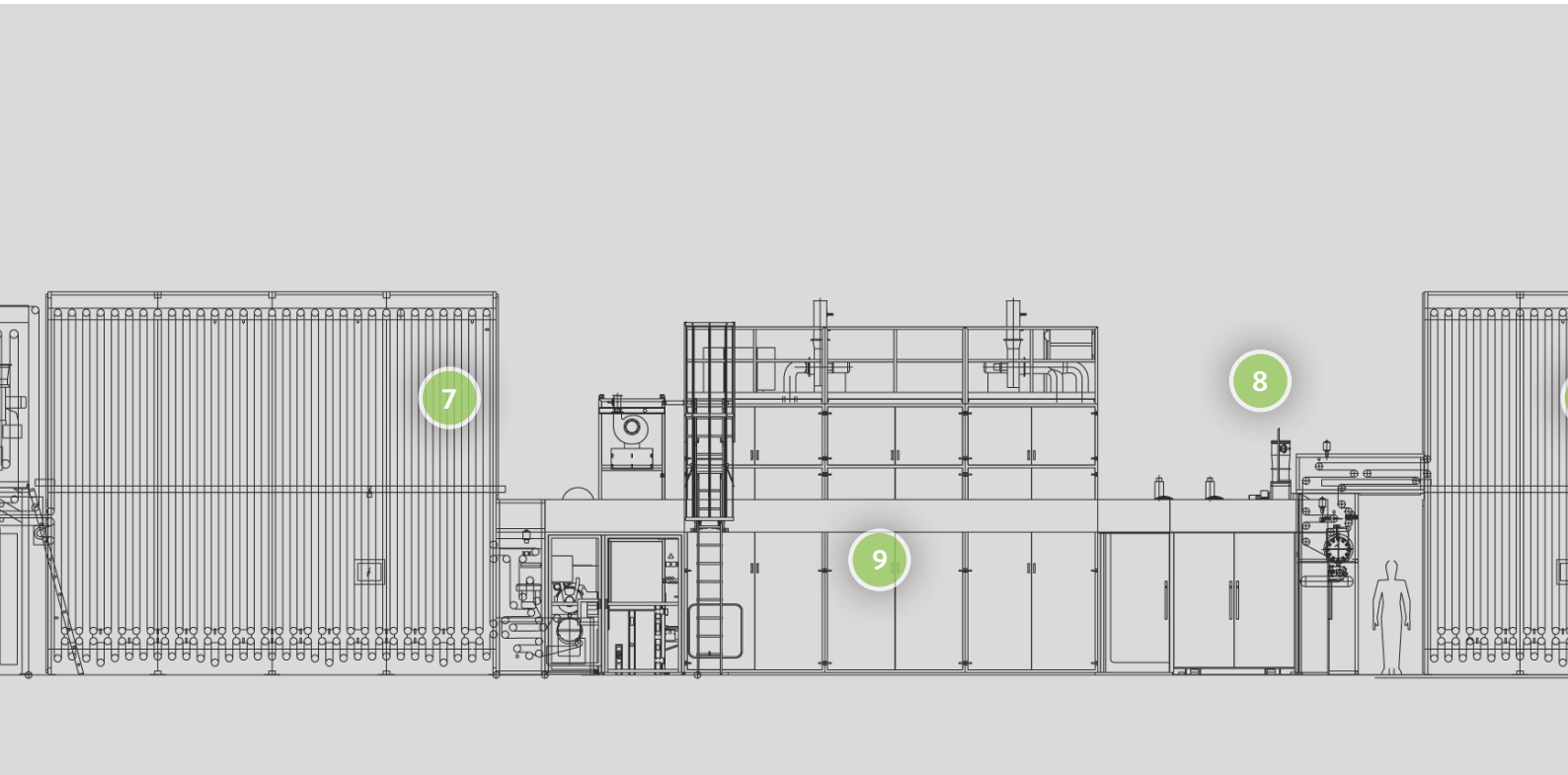

8 Internal coater

Applies a functional lacquer to seal the inside of the cylinder using moveable spray lances.



7 Accumulator

Ensures non-stop production operations by synchronising the line speed and emptying the preceding machine in the event of a machine stop.



6 Washer + dryer

The cylinder is cleaned from lubricant and dust in washing and rinsing cabins. The nozzle injection system ensures optimum cleaning. The cylinders are completely dried in the integrated oven.



5 Pick-up system

A pick-up system removes the cylinders from the bodymaker and pushes them onto a pin chain conveyor.



4 Bodymaker

Within the same movement the cup is redrawn in a first step, is pushed through ironing rings to form a cylinder and the bottom gets its final design. The cylinder is trimmed to the correct length and burr free.

If you deal with large lot sizes, less shapes per line and would like to save material, the Hi-Flex DWI200 line is the best choice. This mall//herlan production line produces up to 200 cans per minute in a continuous process. The extremely effective production means that the impressive production volume of 60 to 70 million individual containers is produced annually. The DWI frontend is followed by decoration and shaping/necking to complete the aerosol cans or bottles. mall//herlan's expertise is underlined by over 100 years of experience in the field of mechanical engineering and manufacturing of machines.

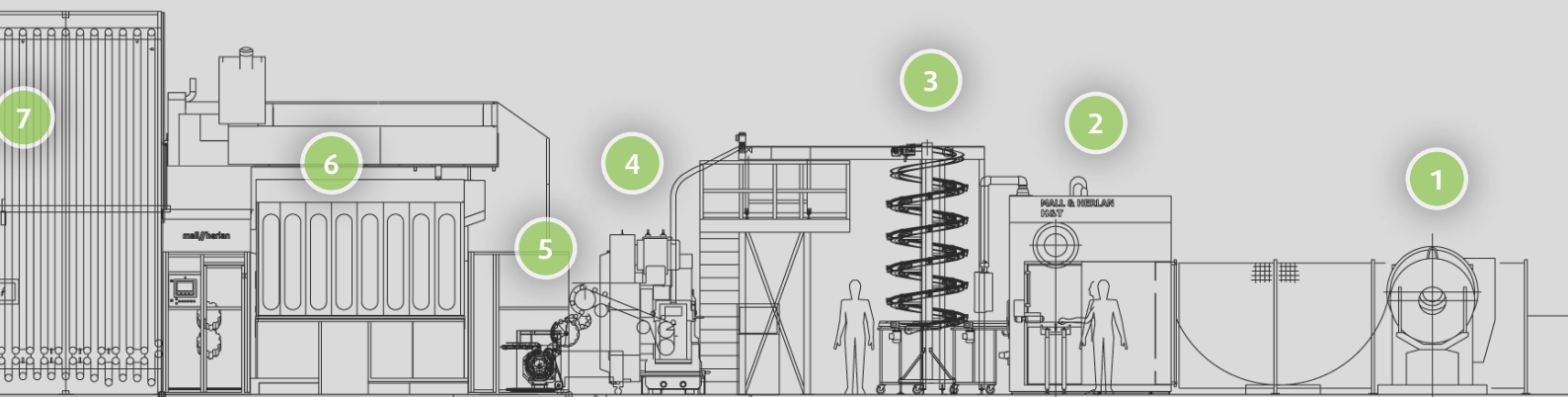

Example layout Aluminium DWI-Line



3 Cup transfer

A conveyor system transports the upright cups on a buffer belt and feeds the cups into the bodymaker.



2 Cupper

The toolholder with a variable number of active tool elements can be exchanged very easily to produce different diameters and lengths. The uncoiled metal is pulled into the press. During this process it moves transversally for most efficient material utilisation.



1 Upender + uncoiler

The aluminium or steel coil is moved from the upender onto the uncoiler and is then transferred to the cupper.

Can data	
Diameter range mm	45 – 66
Max. extruded length mm	250
Max. trimmed length mm	235
Max. production speed cpm	200

Mall + Herlan GmbH
Wöschbacher Strasse 33
DE-76327 Pfinztal

Phone +49 721 946 010
Fax +49 721 946 01 99

info@mall-herlan.com
www.wifag-polytype.com

Mall Herlan MB GmbH
Neuhausen ob Eck/Germany