

HC 130



The compact compression
moulding header and capper

A new dimension in tube making

- // Top quality tube shoulders made by compression moulding
- // Long process time for heading process, ensure a precise shoulder shape and smooth capping application
- // One continuous extrusion and donut dosing system for consistent shoulder quality
- // Small footprint

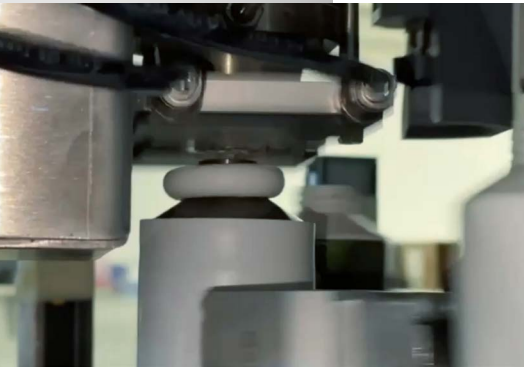

Specification of HC 130

- // \varnothing Sleeve/Tube Diameter: (13.5) 19 - 50 (60) mm
- // Sleeve length: 50 - 215 mm
- // Tube shoulder height: 8 - 35 mm
- // \varnothing Cap diameter: 16 - 50 mm
- // Cap height: 10 - 40 mm
- // Production speed up to: 130 / min

Operations on HC 130

- // Sleeve positioning according to a I-mark
- // Shoulder shaping with compression moulding
- // Membrane sealing
- // Screw on cap or snap on cap with positioning
- // Process control and super vision

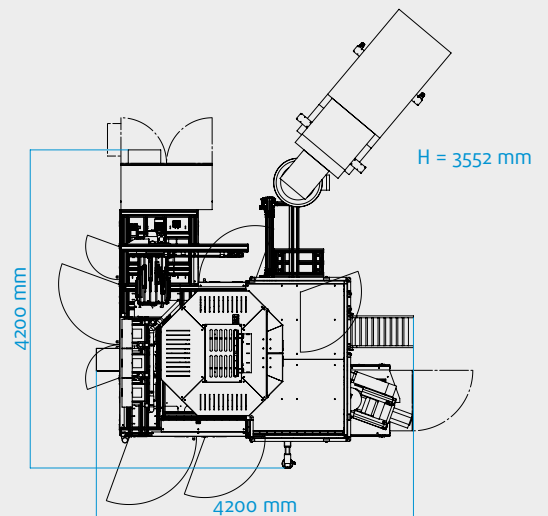

Polytype AG
26, route de la Glâne · CH-1701 Freiburg/Switzerland · Phone +41 26 426 11 11
info@polytype.com · www.polytype.com