

BDM 681/682 – perfect timing

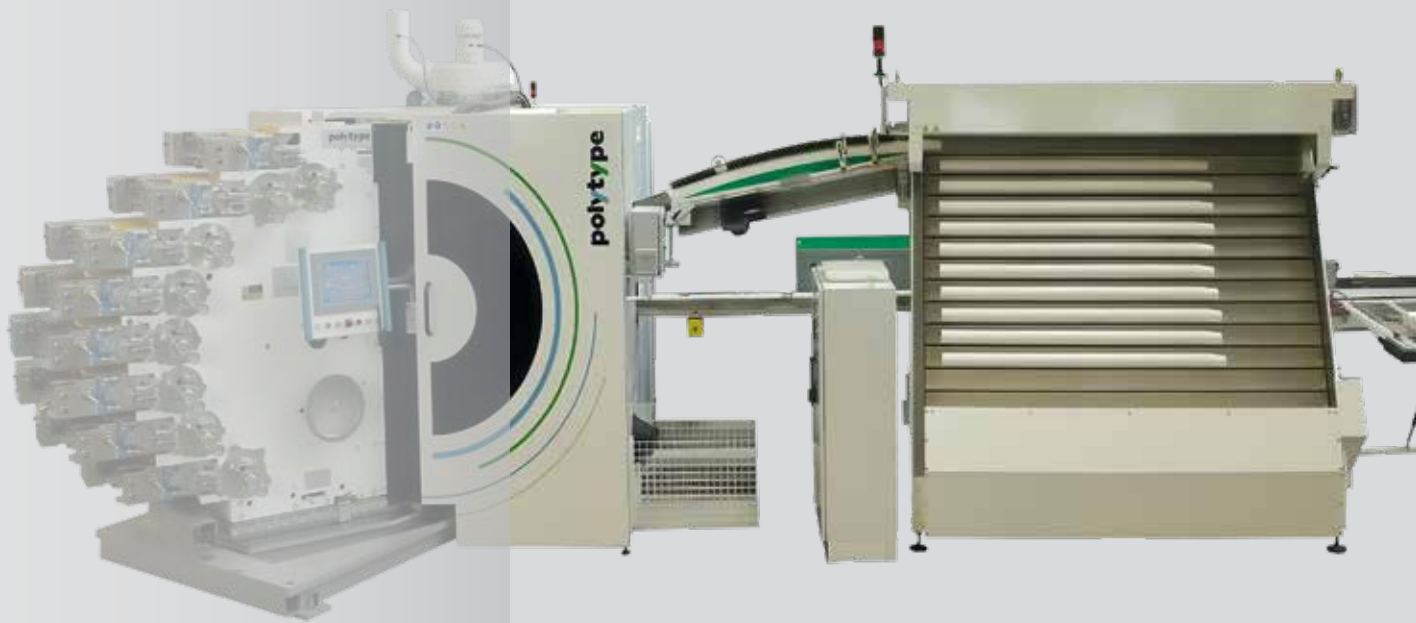

High-performance machine
for round cups

 polytype

Always well-rounded



//polytype is the world leader in the manufacture of systems for direct printing of plastic cups and lids.

//polytype machines combine innovative technology with the highest levels of reliability complemented by the most user-friendly operation. Its international customers appreciate the modularity of the design and the expansion opportunities of the machines.

//polytype is part of the Swiss wifag//polytype Group, which operates globally and has branches in Switzerland, Germany, Italy, Bulgaria, USA and Thailand. This alliance gives //polytype access to a broad technology base and guarantees a global and professional partnership for your success.

- // High productivity
- // Fast changeover
- // Perfect cost/benefit ratio
- // Very user-friendly
- // Wide variety of products

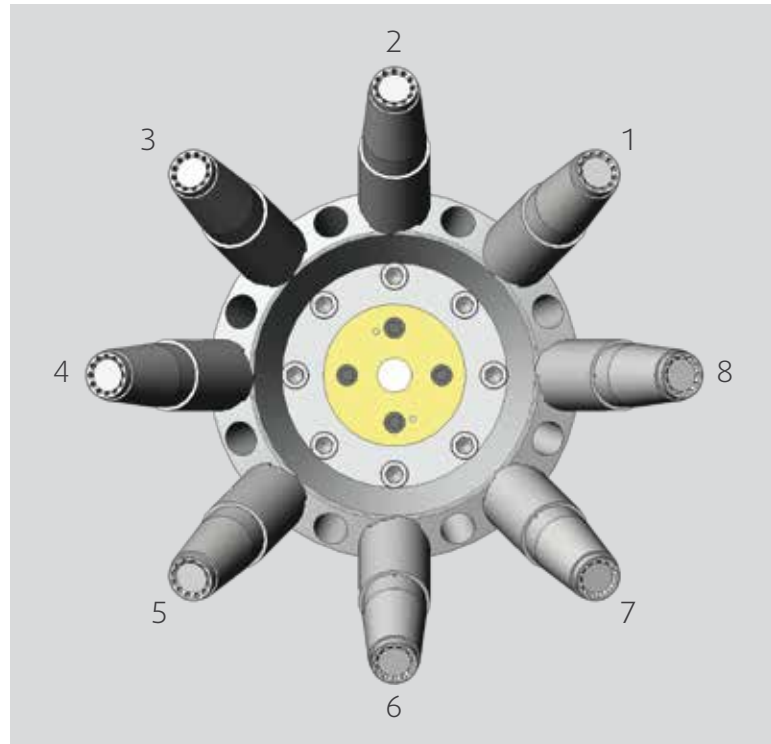
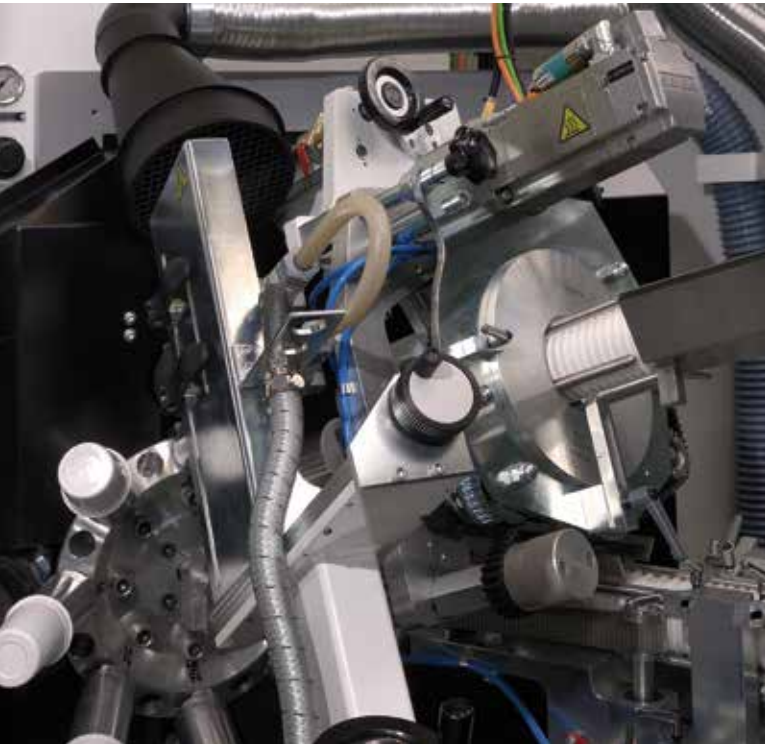

Loading / unloading

Cup feeding station with servo-driven screws. The station can be opened easily for simple access and a fast changeover.

Cup belt take-off system (standard) or system with screws with mechanical read-outs for easy adjustment.

Station set-up for the BDM 681/682

- 1 - Cup loading / Cup & double cup presence control
- 2 - Pre-treatment by corona or gas
- 3 - Not occupied / Option - bottom labelling
- 4 - Printing / Option - pre-print / Option - positioning for 2k or 3k cups
- 5 - Not occupied / Option - vision control
- 6 - UV-curing
- 7 - Ejection
- 8 - Cup take-off / Option - positioning for 2k or 3k cups

Please note: certain option combinations are not possible

Perfect timing – fast, reliable and accurate



The //polytype BDM 681/682 is very user-friendly and designed for one-man operation. All main components are easily accessible and every inking unit can be swung out individually. Functions such as automatic washing and pre-inking of inking units are available to cut changeover times. All register settings can be made on the fly.

A large multifunctional touchscreen operator panel makes for simple machine control. It can be used to save process data and visualize production data and maintenance work. Includes state-of-the-art technology, prepared for industry 4.0.

- // Cleverly designed one-man concept
- // Automatic maintenance display
- // Easy access to all components
- // High reliability



The wide in-feed elevator (2.1 m) with high storage capacity and electronic pusher ensures controlled pressure of cups to feed scrolls. A protective enclosure enables excellent access to the print and transfer areas. The process ends with a discharge table with a precise laser counting device.

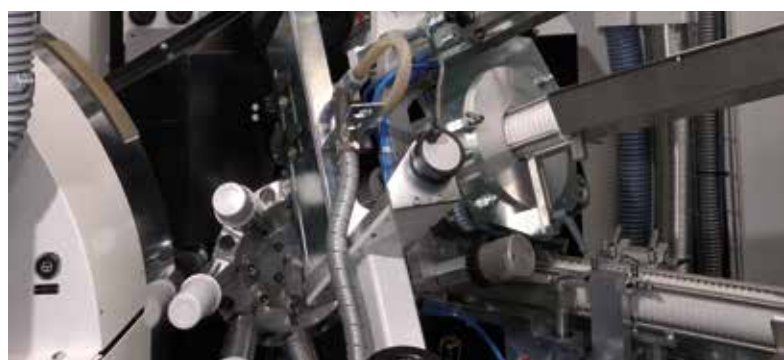

Pre-printing (//polytype patented) – optional

Pre-printing on the //polytype cup printing machine is one of our innovations. The base color is pre-printed and dried immediately in an intermediate stage. This means that print images can be printed on the cup within the same cycle. Pre-printing achieves very high image contrasts and corresponding ink saturation on transparent cups (PP/PS/PET).

This option is available on the //polytype BDM 682. It can also be retrofitted on all previous models.

Good service is worth its weight in gold

- // Optimizing your machine for higher productivity
- // Additional service options
- // Preventive measures to extend the service life of your equipment



Fast changeover

The //polytype BDM 681/682 enables a fast changeover of cup shapes and printing images. A few user-friendly adjustments is all it takes to ready the machine for the next production series. It is based on the easy part changeover, the automatic roller washing and pre-inking.

Positioning – optional

//polytype has developed a positioning system for technically demanding products such as two-compartment containers. In this case, the container is pre-positioned, pre-printed and printed in the printing station in a single pass. The combination of torque drive, pre-printing and positioning system ensures maximum flexibility for cup printing.



Torque motor – optional

As an alternative to traditional mechanical drives comprising indexer, worm gearing and motor, the //polytype BDM 681/682 can be fitted with an electric torque drive to increase the machine's efficiency and flexibility. This solution offers maximum productivity by optimally adjusting the switching angle. It also reduces and optimizes the maintenance requirements.

Excellent service

Productivity is improved thanks to our outstanding service. Our own well-stocked spare parts store ensures quick part replacement if anything should go wrong at any time. Our comprehensive service portfolio ensures you get the best out of your machine at all times. By offering regular maintenance, a hotline service, remote maintenance, and operator and process optimization training, we help you cut costs and improve productivity.

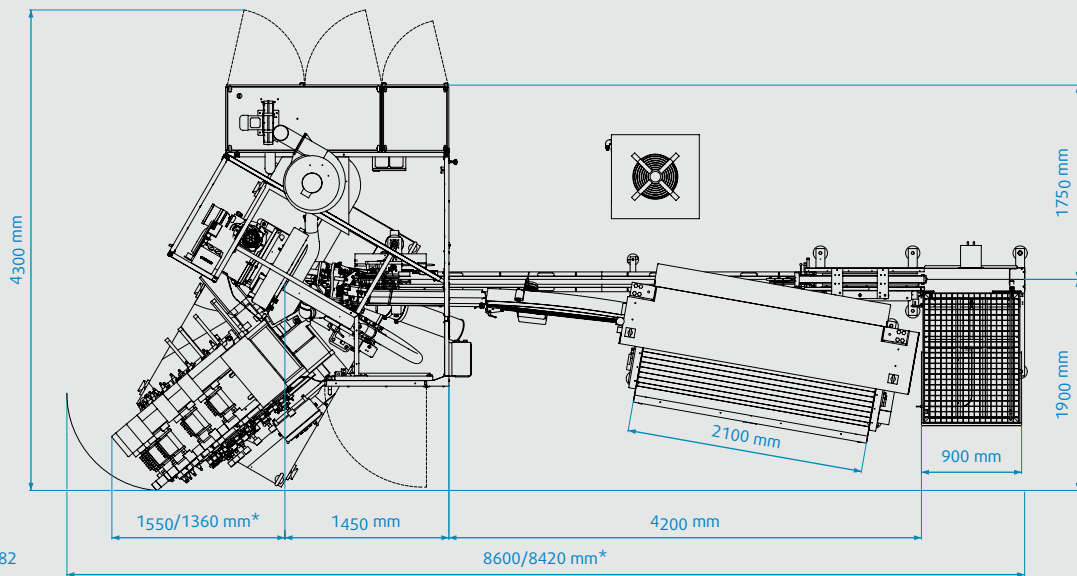
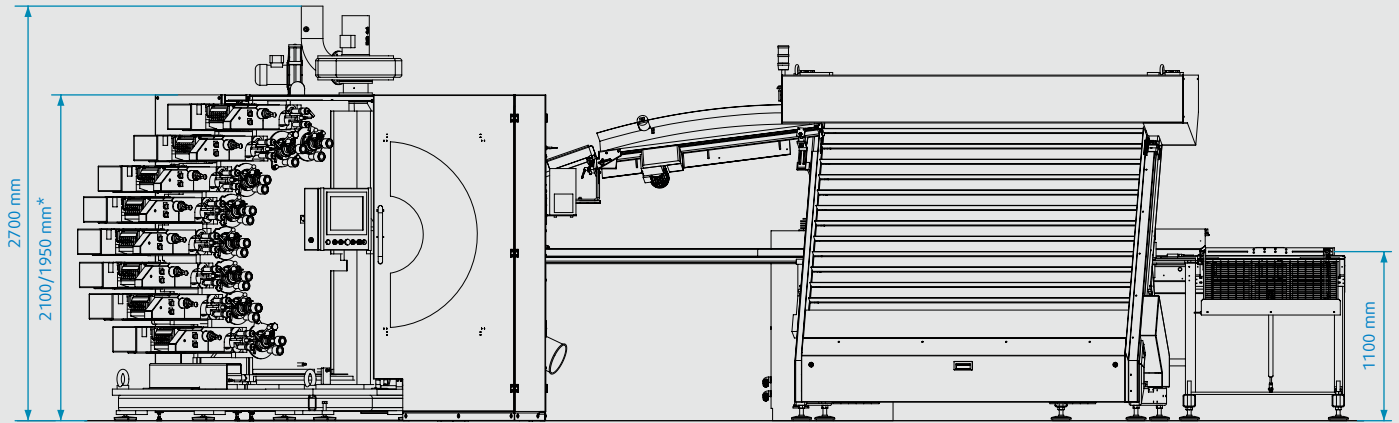

*BDM 681/BDM 682

8600/8420 mm*

Technical data

BDM 681

BDM 682

Min./max. cup height:

35-200 mm

35-200 mm

Min./max. cup diameter:

60-185 mm

60-185 mm

Min./max. taper:

2-15°

2-15°

Max. print height:

145 mm

145 mm

Max. print length:

418 mm

502 mm

Max. printing speed:

650 cups/min

650 cups/min

Weight of main machine:

~ 6000 kg

~ 6500 kg

Polytype AG
26, route de la Glâne
CH-1701 Fribourg/Switzerland

Phone +41 26 426 11 11

info@polytype.com
www.polytype.com

SWITZERLAND

WIFAG-Polytype Holding AG
Fribourg/Switzerland

Polytype AG
Fribourg/Switzerland

AMERICA

Polytype America Corp.
Lincoln Park, NJ/USA

ASIA

Wifag-Polytype India
Marketing Private Ltd.
New Delhi/India

Polytype Asia Pacific Co., Ltd.
Chachoengsao/Thailand

